

STEEL RING GAUGE Large size

Reduced wear SUB-ZERO Treatment·Hardening process

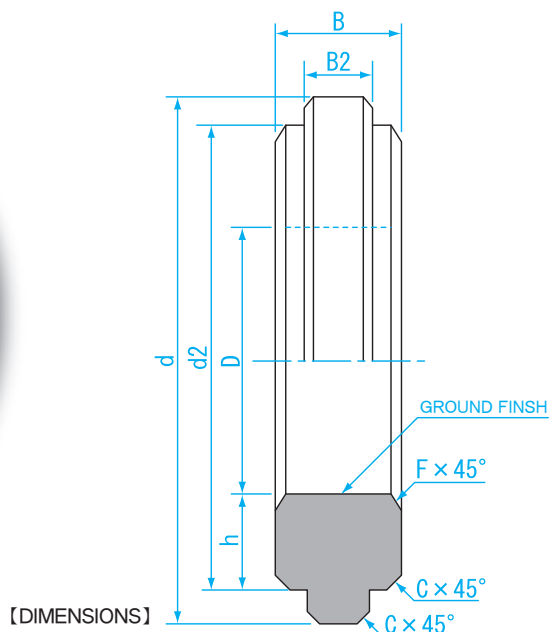

SPECIFICATIONS

Size (mm)	Step (mm)	Out of Roundness (μm)	Out of Cylindricity (μm)	Tolerance (μm)	Hardness (HV)
200 to less 300	10.0 step	5.0	5.0	± 7.0	653 I 772
300 to less 400				± 8.0	
300 to less 400				± 9.0	
500 to less 600				± 10.0	

MATERIAL Alloy tool steel

■ With aluminum case

※ Make-to-order manufacturing

Size List

Size D (mm)	Outside Diameter (mm)		Thickness (mm)		h (mm)	Chamfering for outside diameter C (mm)	Chamfering for inside diameter F (mm)	Remarks	Weight (kg)
	d	d2	B	B2					
200 to less than 230	310	250 - 270	45	25	20	2.0	2.5	NOT Knurled	9 - 10
230 to less than 260	340	280 - 300							11 - 14
260 to less than 290	370	310 - 330							11 - 13
290 to less than 320	400	340 - 360							12 - 14
320 to less than 360	440	380 - 410							14 - 16
360 to less than 400	480	420 - 450							15 - 18
400 to less than 450	540	460 - 500	50	25				19 - 24	
450 to less than 500	600	510 - 550						23 - 29	
450 to less than 500	600	510 - 550						23 - 29	
500 to less than 520	660	560 - 600						27 - 33	