

# CARBIDE RING GAUGE

**LAPPED FINISH**

life span approximately 20 to 30 times grater than steel. Reduced maintenance.

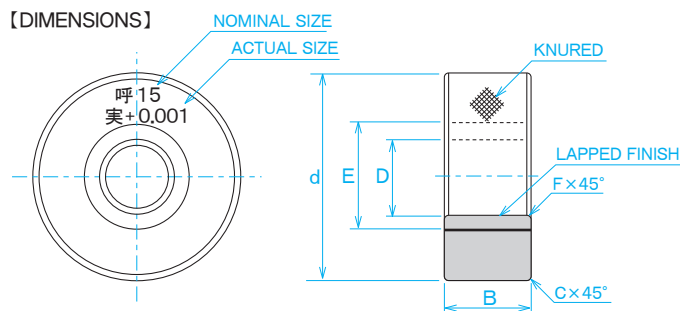
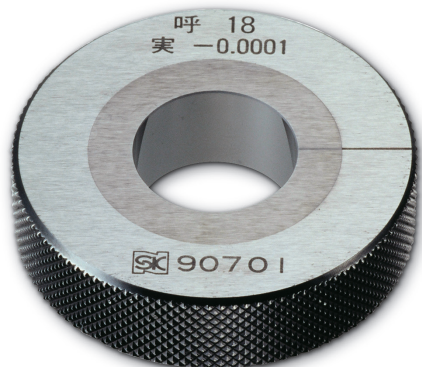

Durable and long life. The coefficient of thermal expansion is small ( $1/2$  of steel,  $5 \times 10^{-6} \text{ K}^{-1}$ ), so better tolerates temperature changes. Less likely to be damaged due to high hardness.  
(Economical- Frequent periodic calibration not required)

**SPECIFICATIONS**

Size (mm)	Step (mm)	Out or Roundness/Cylindricity ( $\mu\text{m}$ )	Tolerance ( $\mu\text{m}$ )
1 to less than 30	—	0.5	$\pm 1$
30 to less than 50	—	0.8	$\pm 1.5$

**MATERIAL** Steel with carbide insert

**Size List**

Size D (mm)	Diameter of Carbide part E (mm)	Outside Diameter d (mm)	Thickness B (mm)	Chamfering for outside Diameter C (mm)	Chamfering for inside Diameter F (mm)
1 to less than 2.5	8	22	4	0.4	0.3
1 to less than 2.5	11		5		
5 to less than 10	16	32	8	0.8	0.5
10 to less than 15	21	38	10	1.2	
15 to less than 20	28	45	12		1.5
20 to less than 25	32	53	14		
25 to less than 32	40	63	16	2.0	
32 to less than 40	50	71	18		
40 to less than 50	60	85	20		

# CERAMIC RING GAUGE

**LAPPED FINISH**

Will not rust or corrode.  
Non magnetic ring gauge.

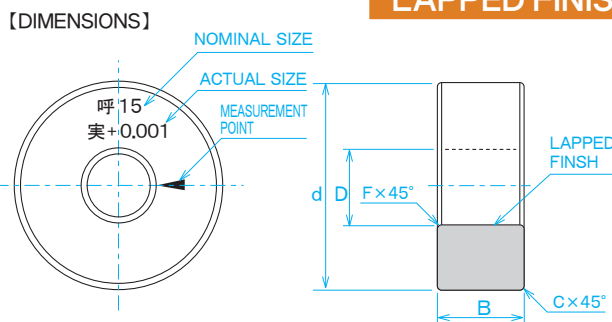
**Size List**

Size D (mm)	Outside Diameter d (mm)	Thickness B (mm)	Chamfering for outside Diameter C (mm)	Chamfering for inside Diameter F (mm)
3 to less than 10	32	8	0.8	0.5
10 to less than 15	38	10	1.2	
15 to less than 20	45	12		1.5
20 to less than 25	53	14		
25 to less than 32	63	16	2.0	
32 to less than 40	71	18		
40 to less than 50	85	20		

Ceramic material is less susceptible to abrasion and age deterioration than steel. Free from rust and corrosion, and easy maintenance.

Non-magnetic body. Does not deform with damage, resists scratches and forming burrs.

●Size is laser marked.

**SPECIFICATIONS**

Size (mm)	Step (mm)	Out or Roundness/Cylindricity ( $\mu\text{m}$ )	Tolerance ( $\mu\text{m}$ )
3 to less than 30	0.5 step	0.5	$\pm 1$
30 to less than 50		0.8	$\pm 1.5$

**Material Data**

List	Material	Ceramic	
		Aluminum	Zircon
Gravity	—	3.8	5.6
Hardness	HV	1500	1100
Bending Strength	MPa	3.9	7~8
Young's modulus	GPa	360	205
Coefficient of thermal expansion	$10^{-6} \text{ K}^{-1}$	8	8
Heat conductivity	W/m·K	29	3.4