

# STEEL RING GAUGE

Reduced wear SUB-ZERO Treatment·Hardening process **Fast Delivery**

Use Ring Gauge as master gauge for "0" adjustment of measuring tools such as bore gauge, inside micrometer, dial caliper, etc.



## SPECIFICATIONS

Size (mm)	Size (mm)	Out of Roundness ( $\mu\text{m}$ )	Out of Cylindricity ( $\mu\text{m}$ )	Tolerance ( $\mu\text{m}$ )	Hardness (HV)
1 to less than 30	0.1 step	0.5	0.5	$\pm 1.0$	653   772
30 to less than 50		0.8	0.8	$\pm 1.5$	
50 to less than 60	0.5 step	1.0	1.0	$\pm 2.0$	
60 to less than 80		1.0	1.0	$\pm 2.0$	
80 to less than 100	5.0 step	2.0	2.0	$\pm 5.0$	
100 to less than 200		2.0	2.0	$\pm 5.0$	

**MATERIAL** Alloy tool steel

## [DIMENSIONS]

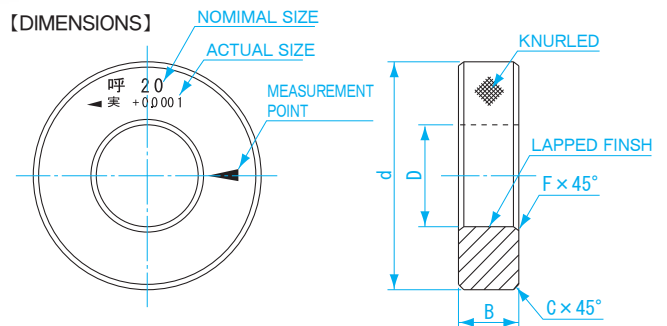

## Stock available size

Size (mm)	Step (mm)	Step (mm)
1 to less than 50	0.1 step	1.0 · 1.1 · 1.2 · 1.3 · 1.4 · 1.5 · 1.6 · 1.7 · 1.8 · 1.9 · 2.0 · 2.1 · 2.2 · 2.3 · 2.4 · 2.5 · 2.6 · 2.7 · ..... · 50.0
50 to less than 100	0.5 step	50.5 · 51.0 · 51.5 · 52.0 · 52.5 · 53.0 · 53.5 · 54.0 · 54.5 · 55.0 · 55.5 · 56.0 · 56.5 · 57.0 · 57.5 · ..... · 100.0
100 to less than 200	5.0 step	105.0 · 110.0 · 115.0 · 120.0 · 125.0 · 130.0 · 135.0 · 140.0 · 145.0 · 150.0 · 155.0 · 160.0 · 165.0 · ..... · 200.0

## Size List

Size D (mm)	Outside Diameter d (mm)	Thickness B (mm)	Chamfering for outside diameter C (mm)	Chamfering for inside diameter F (mm)	Remarks	Weight
1 to less than 2.5	22	4	0.4	0.3	Knurled	10g
2.5 to less than 5		5				10g
5 to less than 10	32	8	0.8	0.5		50g
10 to less than 15	38	10				80g
15 to less than 20	45	12	1.2	1.0		100g
20 to less than 25	53	14				200g
25 to less than 32	63	16	1.5	1.0		300g
25 to less than 32	71	18				400g
40 to less than 50	85	20	2.0	1.5		600 - 700g
50 to less than 60	100	24				0.9 - 1.1kg
60 to less than 70	112		24	2.0	1.5	1.1 - 1.3kg
70 to less than 80	125	1.4 - 1.6kg				
80 to less than 90	140	35	2.4	1.5	1.7 - 1.9kg	
90 to less than 100	160				2.3 - 2.6kg	
100 to less than 110	180	30	2.4	1.5	3.7 - 4.1kg	
110 to less than 120	190				4.7 - 5.1kg	
120 to less than 130	200	38	2.4	1.5	5.0 - 5.5kg	
130 to less than 140	210				5.7 - 6.3kg	
140 to less than 160	230	40	2.0	2.0	6.6 - 8.2kg	
160 to less than 180	260				8.6 - 10kg	
180 to less than 200	280				9.4 - 11kg	

## STEEL RING GAUGE SET

### Set List

Model No.	Nominal Size	Pin per set
RG-1	1.0 · 1.5 · 2.0 · 2.5 · 3.0 · 4.0 · 5.0 · 6.0 · 7.0 · 8.0 · 9.0 · 10.0	12
RG-2	11.0 · 12.0 · 13.0 · 14.0 · 15.0 · 16.0 · 17.0 · 18.0 · 19.0 · 20.0 · 22.0 · 24.0	12
RG-3	25.0 · 26.0 · 27.0 · 28.0 · 30.0 · 32.0 · 34.0 · 35.0 · 36.0 · 37.0 · 38.0 · 40.0	12
RG-4	42.0 · 44.0 · 45.0 · 46.0 · 47.0 · 48.0 · 50.0	7
RG-5	52.0 · 54.0 · 55.0 · 56.0 · 58.0 · 60.0 · 65.0	7
RG-6	68.0 · 70.0 · 75.0 · 80.0	4
RG-7	85.0 · 90.0 · 95.0 · 10.0	4